

SENIOR MATHEMATICAL CHALLENGE

Organised by the United Kingdom Mathematics Trust



SOLUTIONS AND INVESTIGATIONS

These solutions augment the printed solutions that we send to schools. For convenience, the solutions sent to schools are confined to two sides of A4 paper and therefore in many cases are rather short. The solutions given here have been extended. In some cases we give alternative solutions, and we have included some problems for further investigation. We welcome comments on these solutions. Please send them to enquiry@ukmt.org.uk.

The Senior Mathematical Challenge (SMC) is a multiple-choice paper. For each question, you are presented with five options, of which just one is correct. It follows that often you can find the correct answers by working backwards from the given alternatives, or by showing that four of them are not correct. This can be a sensible thing to do in the context of the SMC.

However, this does not provide a full mathematical explanation that would be acceptable if you were just given the questions without any alternative answers. So we aim at including for each question a complete solution with all steps explained, and not based on the assumption that one of the given alternatives is correct. In some cases we have added a commentary to indicate the sort of thinking that led to our solution. You should not include commentary of this kind in your written solutions, but we hope that these solutions, without the commentary, provide a model for the type of written solution that is expected when presenting a complete solution to a mathematical problem (for example, in the British Mathematical Olympiad, the Mathematical Olympiad for Girls and similar competitions).

These solutions may be used freely within your school or college. You may, without further permission, post these solutions on a website that is accessible only to staff and students of the school or college, print out and distribute copies within the school or college, and use them in the classroom. If you wish to use them in any other way, please consult us. © UKMT November 2016

Enquiries about the Senior Mathematical Challenge should be sent to:

*SMC, UKMT, School of Mathematics Satellite, University of Leeds,
Leeds LS2 9JT*

☎ 0113 343 2339 enquiry@ukmt.org.uk www.ukmt.org.uk

1 2 3 4 5 6 7 8 9 10 11 12 13 14 15 16 17 18 19 20 21 22 23 24 25
B D B C A D A B C B E C A D B D D E D E C C E B D

1. How many times does the digit 9 appear in the answer to $987\,654\,321 \times 9$?

- A 0 B 1 C 5 D 8 E 9

SOLUTION **B**

There seems no better method here than just doing the multiplication.

$$9 \times 987\,654\,321 = 8\,888\,888\,889.$$

So the number of times that the digit 9 occurs in the answer is 1.

2. On a Monday, all prices in Isla’s shop are 10% more than normal. On Friday all prices in Isla’s shop are 10% less than normal. James bought a book on Monday for £5.50. What would be the price of another copy of this book on Friday?

- A £5.50 B £5.00 C £4.95 D £4.50 E £4.40

SOLUTION **D**

The book cost £5.50 on a Monday after prices have risen by 10%. Therefore the price before this increase was £5. It follows that on a Friday, after prices have been cut by 10%, the price of the book has fallen by 50p to £4.50.

3. The diagram shows a circle with radius 1 that rolls without slipping around the inside of a square with sides of length 5.

The circle rolls once around the square, returning to its starting point.

What distance does the centre of the circle travel?

- A $16 - 2\pi$ B 12 C $6 + \pi$ D $20 - 2\pi$
E 20

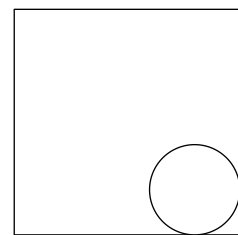

SOLUTION **B**

As the circle rolls, its centre is always at a distance 1 from the square. Therefore, as shown in the diagram, the centre traces out a square whose side length is 2 less than the side length of the square. It follows that the centre travels a distance equal to the length of the perimeter of a square with side length 3.

We deduce that the distance that the centre travels is 12.

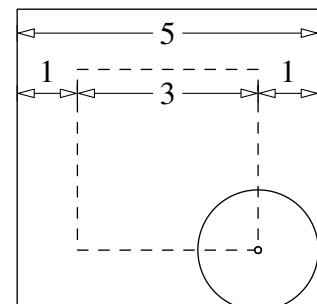

FOR INVESTIGATION

3.1 How far would the centre of the circle travel if it rolls once without slipping around the inside of an equilateral triangle with sides of length 5? What if it rolls *outside* the triangle?

4. Alex draws a scalene triangle. One of the angles is 80° .

Which of the following could be the difference between the other two angles in Alex's triangle?

A 0°

B 60°

C 80°

D 100°

E 120°

SOLUTION

C

All the side lengths of a scalene triangle are different, therefore all the angles are different.

It follows that the difference between two of the angles cannot be 0° . This rules out option A.

The sum of the angles in a triangle is 180° . Therefore, as one of the angles in Alex's triangle is 80° , the sum of the other two angles is 100° . It follows that the difference between these angles is less than 100° . This rules out options D and E.

If the two angles with sum 100° have a difference of 60° , these angles would be 80° and 20° . So the triangle would have two angles of 80° , which is impossible for a scalene triangle. This rules out option B.

Therefore the correct option is C, since it is the only one we have not eliminated.

NOTE

In the context of the SMC it is adequate to stop here. Once four of the options have been eliminated, the remaining option must be correct.

However, for a full solution you would need to show that it is possible for the difference between the other two angles to be 80° . You are asked to do this in Exercise 4.1, below.

FOR INVESTIGATION

4.1 What are the angles of a scalene triangle in which one angle is 80° and the difference between the other two angles is 80° ?

4.2 Show that, as stated in the solution, if two angles have sum 100° and difference 60° , then the two angles are 80° and 20° .

4.3 The argument used in the solution above is based on the fact that

In a scalene triangle (that is, a triangle where all the side lengths are different) all the angles are different.

Prove that this is correct.

5. All the digits 2, 3, 4, 5 and 6 are placed in the grid, one in each cell, to form two three-digit numbers that are squares.

Which digit is placed in the centre of the grid?

- A 2 B 3 C 4 D 5 E 6

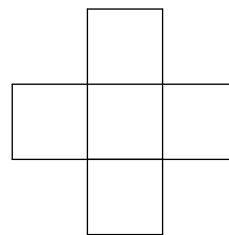

SOLUTION

A

The three-digit squares use just the digits 2, 3, 4, 5 and 6. The smallest square which uses these digits is $15^2 = 225$ and the largest is $25^2 = 625$. However, the squares that go in the grid cannot repeat digits. Therefore the only squares that we need consider are the three-digit squares that use three of digits 2, 3, 4, 5 and 6, once each. It may be checked (see Exercise 5.1, below) that there are just three squares which meet these conditions. They are $16^2 = 256$, $18^2 = 324$ and $25^2 = 625$.

The digit 2 occurs twice as the tens digit of these three squares. Therefore, the digit that goes in the central square of the grid is 2.

In the context of the SMC we could stop here. However, for a complete solution you would need to add that, as the squares 324 and 625 use each of the digits 3, 4, 5 and 6 just once, it is possible to place the digits in the grid so as to make these squares. The diagram shows one way to do this.

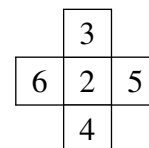

FOR INVESTIGATION

- 5.1** Check that 16^2 , 18^2 and 25^2 are the only three-digit squares using just digits from the list 2, 3, 4, 5, 6, without any repeats.
- 5.2** Arrange the digits 2, 4, 7, 8, 9 in the grid given in the question so as to form two three-digit squares.
- 5.3** Arrange the digits 1, 2, 3, 4, 5 in the grid given in the question so as to form one three-digit square and one three-digit cube.
- 5.4** Which three digits may be used to make three different three-digit squares?
- 5.5** List all the three-digit squares. Which digits occurs least often and most often in this list?

6. The diagram shows a square $ABCD$ and a right-angled triangle ABE . The length of BC is 3. The length of BE is 4.

What is the area of the shaded region?

- A $5\frac{1}{4}$ B $5\frac{3}{8}$ C $5\frac{1}{2}$ D $5\frac{5}{8}$ E $5\frac{3}{4}$

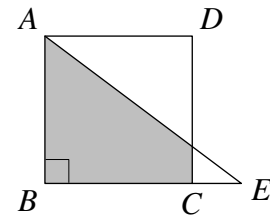

SOLUTION

D

We let F be the point where the lines AE and CD meet.

Because $ABCD$ is a square, $\angle BCF = 90^\circ$. It follows, because angles on a line have sum 180° , that $\angle FCE = 90^\circ$.

Hence, in the triangles ABE and FCE we have $\angle ABE = \angle FCE = 90^\circ$. Also, we see that $\angle BEA = \angle CEF$. It follows that these triangles are similar.

Therefore

$$\frac{FC}{AB} = \frac{CE}{BE}. \quad (1)$$

Because $ABCD$ is a square $AB = BC = 3$. We also have $BE = 4$. Therefore $CE = BE - BC = 4 - 3 = 1$.

It follows from equation (1) that

$$\frac{FC}{3} = \frac{1}{4}.$$

Hence $FC = \frac{3}{4}$.

The shaded region $ABCF$ is a trapezium. The area of a trapezium is given by the formula $\frac{1}{2}h(a + b)$, where a and b are the lengths of the parallel sides, and h is the distance between these sides. It follows that the area of the trapezium $ABCF$ is given by

$$\frac{1}{2}BC(AB + FC) = \frac{1}{2}(3 \times (3 + \frac{3}{4})) = \frac{1}{2}(3 \times \frac{15}{4}) = \frac{45}{8} = 5\frac{5}{8}.$$

FOR INVESTIGATION

- 6.1 The solution above uses the formula $\frac{1}{2}h(a + b)$ for the area of a trapezium. Show that this formula is correct.
- 6.2 Suppose that BE has length 5. What is the area of the trapezium $ABCF$ in this case?
- 6.3 Suppose that BE has length x , where $x > 3$. Find a formula for the area of the trapezium $ABCF$ in terms of x . What happens to this area as x gets larger and larger?

7. Which of these has the smallest value?

A 2016^{-1}

B $2016^{-1/2}$

C 2016^0

D $2016^{1/2}$

E 2016^1

SOLUTION

A

METHOD 1

We have $2016^{-1} = \frac{1}{2016}$ and $2016^{-1/2} = \frac{1}{\sqrt{2016}}$. Now, as $1 < \sqrt{2016} < 2016$, it follows that $\frac{1}{2016} < \frac{1}{\sqrt{2016}} < 1$, and hence $2016^{-1} < 2016^{-1/2} < 1$.

On the other hand, 2016^0 is equal to 1, and both $2016^{1/2} = \sqrt{2016}$ and $2016^1 = 2016$ are greater than 1.

It follows that, of the given options, 2016^{-1} has the smallest value.

METHOD 2

The function 2016^x may be defined by the equation

$$2016^x = e^{x \ln 2016},$$

where e^x is the exponential function [see the note below] and $\ln 2016$ is the natural logarithm of 2016. (The value of $\ln 2016$ is 7.6089 to 4 decimal places.)

The exponential function is an *increasing function* in the sense that if $x < x'$, then $e^x < e^{x'}$. It follows that 2016^x is also an increasing function, because if $x < x'$, then $x \ln 2016 < x' \ln 2016$ and hence $e^{x \ln 2016} < e^{x' \ln 2016}$.

Therefore, as $-1 < -\frac{1}{2} < 0 < \frac{1}{2} < 1$, we have $2016^{-1} < 2016^{-1/2} < 2016^0 < 2016^{1/2} < 2016^1$.

Hence, of the given options, 2016^{-1} is the smallest.

NOTE

The definition of e^x for a general real number x is quite complicated.

One way to define it is by means of an infinite series, as follows.

$$e^x = 1 + x + \frac{x^2}{2!} + \frac{x^3}{3!} + \cdots + \frac{x^n}{n!} + \cdots$$

If we adopt the conventions that $x^0 = 1$ and $0! = 1$, this may be rewritten as

$$e^x = \frac{x^0}{0!} + \frac{x^1}{1!} + \frac{x^2}{2!} + \frac{x^3}{3!} + \cdots + \frac{x^n}{n!} + \cdots,$$

or, using the *sigma notation*, as

$$e^x = \sum_{n=0}^{\infty} \frac{x^n}{n!}.$$

8. Points are drawn on the sides of a square, dividing each side into n equal parts (so, in the example shown, $n = 4$). The points are joined in the manner indicated, to form several small squares (24 in the example, shown shaded) and some triangles.

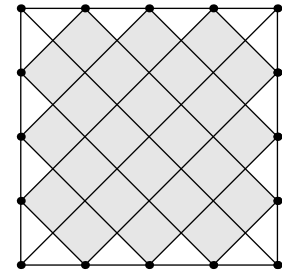

How many small squares are formed when $n = 7$?

- A 56
- B 84
- C 140
- D 840
- E 5040

SOLUTION

B

The main diagonals of the square shown in the question divide the square into four quarters each of which contains $1 + 2 + 3$ small squares. So the number of small squares when $n = 4$ is $4 \times (1 + 2 + 3) = 4 \times 6 = 24$, as the question says.

It can be seen from the diagram on the right that, similarly, when $n = 7$ the number of small squares is given by $4 \times (1 + 2 + 3 + 4 + 5 + 6) = 4 \times 21 = 84$.

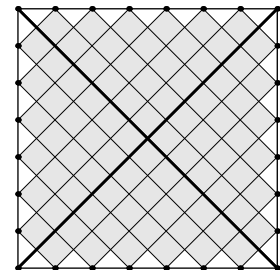

FOR INVESTIGATION

- 8.1 What fraction of the area of the big square is covered by the small squares in the case when $n = 4$?
- 8.2 What fraction of the area of the big square is covered by the small squares in the case when $n = 7$?
- 8.3 Find a formula, in terms of n , for the number of small squares.
- 8.4 Find a formula, in terms of n , for the fraction of the area of the square that is covered by the small squares. What happens to this fraction as n gets larger and larger?

9. A square has vertices at $(0,0)$, $(1,0)$, $(1,1)$ and $(0,1)$. Graphs of the following equations are drawn on the same set of axes as the square.

$$x^2 + y^2 = 1, \quad y = x + 1, \quad y = -x^2 + 1, \quad y = x, \quad y = \frac{1}{x}$$

How many of the graphs pass through exactly two of the vertices of the square?

A 1

B 2

C 3

D 4

E 5

SOLUTION

C

METHOD 1

One method is to draw the graphs.

The graph of the equation $x^2 + y^2 = 1$ is the circle with centre $(0, 0)$ and radius 1. [By Pythagoras' Theorem, the distance, d of the point with coordinates (x, y) from the point $(0, 0)$ is given by the equation $x^2 + y^2 = d^2$. Therefore the equation $x^2 + y^2 = 1$ is satisfied by those points whose distance from the origin, $(0, 0)$ is 1. These are the points on the circle with centre $(0, 0)$ and radius 1, as shown in the diagram below.]

The graph of $y = x + 1$ is the straight line with slope 1 that meets the y -axis at the point $(0, 1)$.

The graph of $y = -x^2 + 1$ is a \cap -shaped parabola which is symmetrical about the y -axis and goes through the point $(0, 1)$.

The graph of $y = x$ is the straight line with gradient 1 which goes through the point $(0, 0)$.

The graph of $y = \frac{1}{x}$ is a rectangular hyperbola with the x -axis and y -axis as its asymptotes. In the diagram below we have just shown part of one arm of this hyperbola.

These graphs are shown in the diagram below.

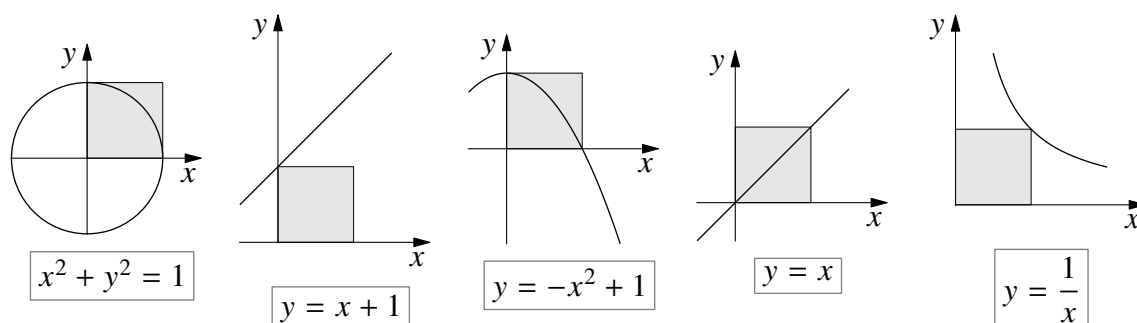

From these graphs we see that the graphs of $x^2 + y^2 = 1$, $y = -x^2 + 1$ and $y = x$ pass through two vertices of the square, whereas each of the other graphs passes through just one vertex of the square.

Hence the number of graphs that pass through exactly two vertices of the square is 3.

NOTE

The solution above assumes that we have drawn the graphs correctly. For a more rigorous method, see the solution below.

METHOD 2

We check whether a given graph passes through a particular vertex of the square, by seeing whether the coordinates of the vertex satisfy the equation of the graph.

For example, when $x = 0$ and $y = 0$ we have $x^2 + y^2 \neq 1$. Therefore the graph of $x^2 + y^2 = 1$ does not go through the vertex $(0, 0)$.

On the other hand, when $x = 0$ and $y = 1$, we have $x^2 + y^2 = 1$. Therefore the graph of $x^2 + y^2 = 1$ does go through the vertex $(0, 1)$.

In the table below we have shown the outcome of all these calculations. We have put ‘yes’ if the graph goes through the vertex in question, and ‘no’ if it does not.

vertices	$x^2 + y^2 = 1$	$y = x + 1$	$y = -x^2 + 1$	$y = x$	$y = \frac{1}{x}$
$(0,0)$	no	no	no	yes	no
$(1,0)$	yes	no	yes	no	no
$(1,1)$	no	no	no	yes	yes
$(0,1)$	yes	yes	yes	no	no

We see that in the case of three of the graphs considered, there are exactly two occurrences of ‘yes’ in the relevant column. We deduce that the number of graphs that pass through exactly two vertices of the square is 3.

FOR INVESTIGATION

- 9.1** Check that all the entries in the table above are correct.
- 9.2** Find a graph that goes through all four of the vertices of the square. You should describe the graph geometrically and also find its equation.
- 9.3** (Harder) Find a graph that goes through exactly three of the vertices of the square. You should describe the graph geometrically and also find its equation.

10. The digits from 1 to 9 are to be written in the nine cells of the 3×3 grid shown, one digit in each cell.

The product of the three digits in the first row is 12.

The product of the three digits in the second row is 112.

The product of the three digits in the first column is 216.

The product of the three digits in the second column is 12.

What is the product of the digits in the shaded cells?

A 24

B 30

C 36

D 48

E 140

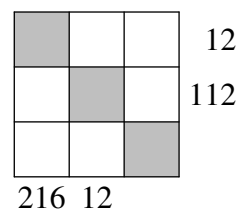

SOLUTION

B

We note first that 112 is divisible by 7, but neither 216 nor 12 is divisible by 7. Therefore, the digit 7 is in the second row but not in the first or second columns. Hence the digit 7 is written in the cell in the second row and third column.

Because $112 = 7 \times 16$, the product of the other two digits in the second row is 16. Since the digits have to be different, these digits are 2 and 8 in some order. Because 8 is not a factor of 12, the digit 8 cannot be in the second column. Therefore 8 is written in the cell in the second row and first column, and 2 is written in the cell in the second row and second column.

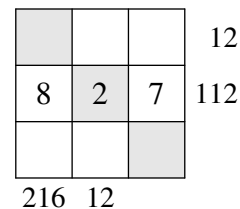

Therefore we know that the second row is as shown in the diagram.

Because $216 = 8 \times 27$, the product of the other two digits in the first column is 27. Hence these digits are 3 and 9. Because 9 is not a factor of 12, the digit 9 cannot be in the first row. Hence 9 is in the first column and third row, and 3 is in the first column and first row.

The product of the three digits in the second column is 12. One of these digits is 2. Hence, the product of the other two digits in the second column is 6. As 2 and 3 are already in the grid, these digits are 1 and 6.

The digit 6 cannot be in the first row, as otherwise the product of the digits in the first row would not be 12. It follows that the digit 1 is in the first row and second column, and 6 is in the third row and second column. The digit in the first row and third column is therefore 4. The remaining digit 5 is in the third row and third column.

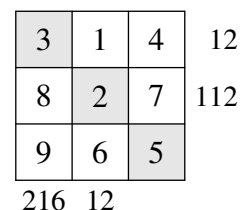

Therefore the digits are written as shown in the diagram. The digits in the shaded squares are 3, 2 and 5. The product of these digits is 30.

FOR INVESTIGATION

10.1 In the above argument, we showed that the digit in the third row and third column is 5 because it was the only digit we had not yet placed. However, it is possible to see that the digit 5 is in this cell before working out where any of the other digits go. Explain how.

10.2 Invent more puzzles of a similar kind to that in this question.

11. In the grid below each of the blank squares and the square marked X are to be filled by the mean of the two numbers in its adjacent squares.

Which number should go in the square marked X ?

10			X		25
----	--	--	-----	--	----

A 15

B 16

C 17

D 18

E 19

SOLUTION

E

We note first that if b is the mean of the numbers a and c , then $b = \frac{1}{2}(a + c)$. Hence $2b = a + c$ and therefore $b - a = c - b$. In other words, the numbers a, b, c form an arithmetic sequence. That is, their differences are equal.

We deduce that, because each number in the grid, other than 10 and 25, is the mean of the two adjacent numbers, the six numbers in the grid form an arithmetic sequence. Suppose that their common difference is d . Then the numbers in the grid will form the sequence $10, 10 + d, 10 + 2d, 10 + 3d, 10 + 4d, 10 + 5d$.

It follows that $10 + 5d = 25$. Hence $d = 3$.

The number which is in the square marked X is $10 + 3d$. Because $d = 3$, this number is 19.

12. Which is the smallest square that has 2016 as a factor?

A 42^2 B 84^2 C 168^2 D 336^2 E 2016^2

SOLUTION

C

An integer is a square if, and only if, the exponent of each prime in its prime factorization is even.

The prime factorization of 2016 is $2^5 \times 3^2 \times 7$.

If 2016 is a factor of a square, then the exponents of the primes 2, 3 and 7 in the factorization of the square must be no smaller than their exponents in 2016.

Hence the smallest square of which 2016 is a factor has the prime factorization $2^a \times 3^b \times 7^c$, where a, b and c are the smallest even integers which are greater than or equal to 5, 2 and 1, respectively. Therefore $a = 6, b = 2$ and $c = 2$. Hence, the smallest square is of which 2016 is a factor is $2^6 \times 3^2 \times 7^2$.

Now

$$2^6 \times 3^2 \times 7^2 = (2^3 \times 3^1 \times 7^1)^2 = (8 \times 3 \times 7)^2 = 168^2.$$

Therefore the smallest square of which 2016 is a factor is 168^2 .

FOR INVESTIGATION

12.1 Check that the prime factorization of 2016 is $2^5 \times 3^2 \times 7$, as given above.

12.2 Explain why *an integer is a square if, and only if, the exponent of each prime in its prime factorization is even.*

12.3 Which is the smallest cube that has 2016 as a factor?

- 13.** Five square tiles are put together side by side. A quarter circle is drawn on each tile to make a continuous curve as shown. Each of the smallest squares has side-length 1.

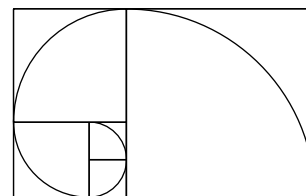

What is the total length of the curve?

- A 6π B 6.5π C 7π D 7.5π
E 8π

SOLUTION

A

The side lengths of the 5 squares are 1, 1, 2, 3 and 5. So the curve is made up of five quarter circles with these radii. The circumference of a circle with radius r is $2\pi r$. Therefore the length of a quarter circle of radius r is $\frac{1}{4}(2\pi r)$, that is, $\frac{1}{2}\pi r$.

Therefore the length of the curve is l , where

$$l = \frac{1}{2}\pi 1 + \frac{1}{2}\pi 1 + \frac{1}{2}\pi 2 + \frac{1}{2}\pi 3 + \frac{1}{2}\pi 5 = \frac{1}{2}\pi(1 + 1 + 2 + 3 + 5) = 6\pi.$$

- 14.** Which of the following values of the positive integer n is a counterexample to the statement: “If n is not prime then $n - 2$ is not prime”?

- A 6 B 11 C 27 D 33 E 51

SOLUTION

D

A *counterexample* to the statement “If n is not prime then $n - 2$ is not prime” is a positive integer n for which this implication is false. An implication of the form “If P then Q ” is false if P is true, but Q is false.

Therefore a counterexample to the statement is a positive integer n for which it is true that n is not prime, but false that $n - 2$ is not prime. In other words, a counterexample is a positive integer n such that n is not prime but $n - 2$ is prime.

Since 11 is prime, option B does not provide the required counterexample.

The options 6, 27, 33 and 51 are not primes. However $6 - 2 = 4$, $27 - 2 = 25$ and $51 - 2 = 49$ are also not primes. Therefore none of the options A, C and E provides the required counterexample.

This leaves $n = 33$. We see that 33 is not prime, but $33 - 2 = 31$, is prime. Therefore 33 is a counterexample. Hence the correct option is D.

FOR INVESTIGATION

- 14.1** Which is the smallest positive integer which provides a counterexample to the statement in the question?
- 14.2** Find the smallest integer which is greater than 33 and is a counterexample to the statement in the question.
- 14.3** Are there infinitely many positive integers n that are counterexamples to the statement in the question?

15. The diagram shows three rectangles and three straight lines.

What is the value of $p + q + r$?

- A 135 B 180 C 210 D 225
E 270

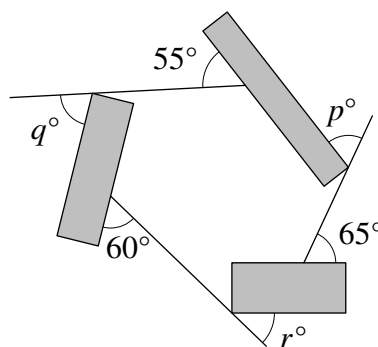

SOLUTION

B

Let P , Q and R be the points shown in the diagram where the rectangles touch the straight lines. Let the straight lines when extended meet the rectangles at the points S , T and U , as shown.

Then $PSQTRU$ is a hexagon. The external angles of this hexagon at the vertices P , Q and R are p° , q° , and r° , respectively, as given. Let the external angles at S , T and U be s° , t° and u° , as shown.

The external angles of a hexagon have sum 360° . Therefore $p + q + r + s + t + u = 360$.

The opposite sides of a rectangle are parallel. When lines are parallel the corresponding angles are equal. Therefore $s = 55$, $t = 60$ and $u = 65$. Hence $s + t + u = 55 + 60 + 65 = 180$.

It follows that $p + q + r = (p + q + r + s + t + u) - (s + t + u) = 360 - 180 = 180$.

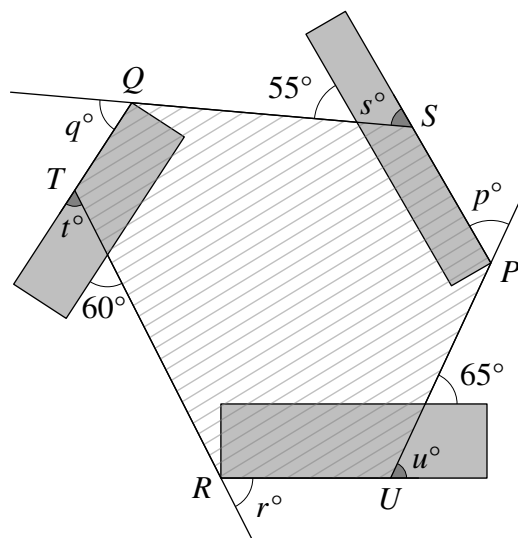

FOR INVESTIGATION

15.1 Explain why the sum of the external angles of a hexagon, and, indeed, of any polygon, is 360° .

16. For which value of k is $\sqrt{2016} + \sqrt{56}$ equal to 14^k ?

- A $\frac{1}{2}$ B $\frac{3}{4}$ C $\frac{5}{4}$ D $\frac{3}{2}$ E $\frac{5}{2}$

SOLUTION

D

We have already seen (in the solution to question 12) that $2016 = 2^5 \times 3^2 \times 7$. It follows that $2016 = (2^4 \times 3^2) \times 2 \times 7 = (2^2 \times 3)^2 \times 2 \times 7 = 12^2 \times 14$. Therefore $\sqrt{2016} = 12\sqrt{14}$.

Also, $\sqrt{56} = \sqrt{2^2 \times 14} = 2\sqrt{14}$. Hence $\sqrt{2016} + \sqrt{56} = 12\sqrt{14} + 2\sqrt{14} = 14\sqrt{14}$.

Now, $14\sqrt{14} = 14^1 \times 14^{1/2} = 14^{1+1/2} = 14^{3/2}$. Therefore $k = \frac{3}{2}$.

17. Aaron has to choose a three-digit code for his bike lock. The digits can be chosen from 1 to 9. To help him remember them, Aaron chooses three different digits in increasing order, for example 278.

How many such codes can be chosen?

A 779

B 504

C 168

D 84

E 9

SOLUTION

D

METHOD 1

We count the number of ways in which Aaron can choose three digits in increasing order.

We first consider the case when the first digit Aaron chooses is 1.

If the second digit he chooses is 2, he has 7 remaining choices for the third digit, namely any of the digits from 3 to 9, inclusive. If the second digit Aaron chooses is 3, he has 6 remaining choices for the third digit, namely any of the digits from 4 to 9, inclusive, and so on. Finally, we see that if the second digit Aaron chooses is 8, he has just one choice, 9, for the third digit. He cannot choose 9 as the second digit, as that would leave no choice for the third digit.

Therefore, the number of different codes with first digit 1 that Aaron can choose is $7 + 6 + 5 + 4 + 3 + 2 + 1$, that is, 28.

Similarly, the number of different codes with first digit 2, that Aaron can choose is $6 + 5 + 4 + 3 + 2 + 1$, that is, 21.

And so on, until finally, if the first digit Aaron chooses is 7, he has just one choice of code, namely 789.

Therefore the total number of codes that Aaron can choose is $28 + 21 + 15 + 10 + 6 + 3 + 1$, that is, 84.

METHOD 2

This method assumes some previous knowledge of *binomial coefficients* (see the note below).

Given any three different non-zero digits, there is only one way in which Aaron can use them to make a code, as he wishes to arrange them in increasing order.

Therefore the number of different codes that Aaron can choose is the number of different ways in which Aaron can choose 3 digits from the 9 non-zero digits. This number, '9 choose 3', is written $\binom{9}{3}$ or sometimes 9C_3 or 9C_3 . The number $\binom{9}{3}$ is the coefficient of x^3 in the expansion of $(1 + x)^9$. It is what is called a *binomial coefficient*.

The general formula for the binomial coefficients is given by $\binom{n}{r} = \frac{n!}{r!(n-r)!}$. Therefore the number of different codes that Aaron can choose is

$$\binom{9}{3} = \frac{9!}{3!6!} = \frac{9 \times 8 \times 7}{3 \times 2 \times 1} = 84.$$

NOTE

The second method uses knowledge of the formula for the binomial coefficient ‘ n choose r ’ which gives the number of ways of choosing r things from a set of n different objects. You may already have met *Pascal’s triangle* which is made up of the binomial coefficients.

The branch of mathematics which covers problems of this kind is called *Combinatorics*. The book *Introduction to Combinatorics* by Gerry Leversha and Dominic Rowland, published by the UKMT in 2015, is an excellent introduction to this subject.

If this book is not yet in your school or college library, suggest that it should be acquired. It may be ordered from the UKMT website.

FOR INVESTIGATION

17.1 How many n -digit codes, for $1 \leq n \leq 9$, can Aaron choose when, for each value of n , the code has to consist of n different digits from 1 to 9 which are arranged in increasing order?

17.2 What do you notice about your answers to 17.1?

18. The circumference of a circle with radius 1 is divided into four equal arcs. Two of the arcs are ‘turned over’ as shown.

What is the area of the shaded region?

- A 1 B $\sqrt{2}$ C $\frac{1}{2}\pi$ D $\sqrt{3}$ E 2

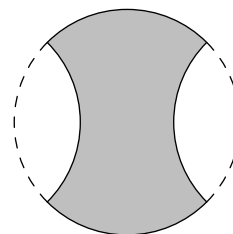

SOLUTION

E

Because the four arcs are equal, their endpoints form a square. This square is shown in the diagram.

The four segments P , Q , R and S , indicated in the diagram, are congruent. The shaded region is made up of the region T , together with the segments P and Q . It follows that the area of this region is equal to that of the square which is made up of T and the two segments R and S .

The diagonals of the square are diameters of the circle. Therefore they have length 2. It follows that the square has sides of length $\sqrt{2}$. Hence the area of the square is $\sqrt{2} \times \sqrt{2}$, that is, 2.

Therefore the area of the shaded region is 2.

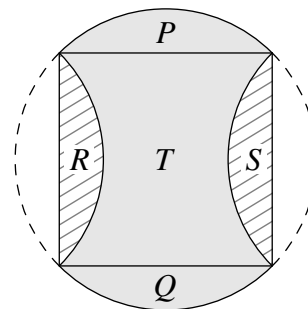

FOR INVESTIGATION

18.1 The above solution uses the fact that because the four arcs are equal, their endpoints form a square. Explain why this follows.

18.2 Explain why it follows from the fact that the diagonals of the square have length 2, that the sides of the square have length $\sqrt{2}$.

19. Let S be a set of five different positive integers, the largest of which is m . It is impossible to construct a quadrilateral with non-zero area, whose side-lengths are all distinct elements of S .

What is the smallest possible value of m ?

A 2

B 4

C 9

D 11

E 12

SOLUTION

D

Let $WXYZ$ be a quadrilateral, with non-zero area. We note first that the shortest route from W to Z is the line segment WZ .

Since $WXYZ$ has non-zero area, the points X and Y are not both on the line segment WZ . Therefore the path made up of the line segments WX , XY and YZ is not the shortest route from W to Z .

It follows that $WX + XY + YZ > WZ$.

Conversely, it may be seen that when the sum of the three smallest of four positive numbers is greater than the largest number of the four, then there is quadrilateral with non-zero area which has these four positive numbers as its side lengths. (You are asked to check this in Exercise 19.1)

Suppose h, j, k, l and m are five positive integers with $h < j < k < l < m$, which have the required property that, whichever four of them are selected, these are not the side lengths of a quadrilateral with non-zero area. Then, whichever four of these numbers are selected, the sum of the three smallest is no greater than the largest.

In Exercise 19.2 you are asked to check that, provided that $h + j + k \leq l$ and $j + k + l \leq m$, the integers h, j, k, l and m satisfy the condition that, whichever four of them are selected, the sum of the three smallest is no greater than the largest.

We wish to choose m to be as small as possible. To achieve this we need h, j, k and l to be as small as possible. The smallest possible values for h, j and k , are $h = 1, j = 2$ and $k = 3$. This gives $h + j + k = 1 + 2 + 3 = 6$. Because we need to have $h + j + k \leq l$, the smallest possible value of l is 6. Then $j + k + l = 2 + 3 + 6 = 11$. Because we need to have $j + k + l \leq m$, the smallest possible value of m is 11.

FOR INVESTIGATION

19.1 Show that if p, q, r and s are positive numbers such that $p < q < r < s$ and $p + q + r > s$, then there is a quadrilateral with non-zero area which has these side lengths. [*Hint*: One method is to show that there is a trapezium whose parallel sides have lengths r and s , and whose other two sides have lengths p and q .]

19.2 Suppose that $h < j < k < l < m$ and $h + j + k \leq l$ and $j + k + l \leq m$. Check that whichever four of the numbers h, j, k, l, m are selected, the sum of the three smallest is no greater than the largest.

19.3 What is the value of m in the similar problem where S is a set of six different positive integers?

20. Michael was walking in Marrakesh when he saw a tiling formed by tessellating the square tile as shown.

The tile has four lines of symmetry and the length of each side is 8 cm. The length of XY is 2 cm. The point Z is such that XZ is a straight line and YZ is parallel to the sides of the square.

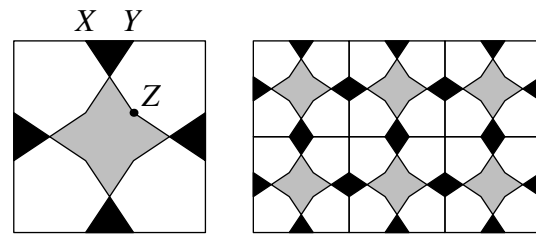

What is the area of the central grey octagon?

- A 6 cm^2 B 7 cm^2 C 8 cm^2 D 9 cm^2 E 10 cm^2

SOLUTION **E**

Let T, U, V and W be the points shown in the diagram.

Because the tile has four lines of symmetry and YZ is parallel to the sides of the square, so also is XU , and $XU = YZ$. Therefore $XUZY$ is a rectangle with $UZ = XY = 2 \text{ cm}$.

Because XZ is a straight line, by the symmetry of the tile, it follows that UY is also a straight line. Therefore XZ and UY are the diagonals of the rectangle $XUZY$ and they divide the rectangle into four triangles with equal areas.

Also, by the symmetry of the tile, $UVWZ$ is a square, XT is a straight line and $XU = VT$. Therefore, because $UV = UZ = 2 \text{ cm}$ and $XT = 8 \text{ cm}$, it follows that $XU = 3 \text{ cm}$.

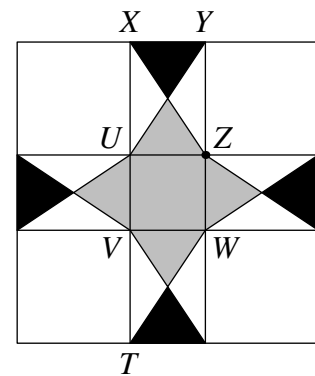

The shaded octagon is made up of the $2 \text{ cm} \times 2 \text{ cm}$ square $UVWZ$ and four congruent triangles. Each of these four triangles has the same area as one quarter of the rectangle $XUZY$. Therefore the area of the shaded octagon equals the area of $UVWZ$ plus the area of the $2 \text{ cm} \times 3 \text{ cm}$ rectangle $XUZY$.

Hence the area of the octagon is $(2 \times 2 + 2 \times 3) \text{ cm}^2$, that is, 10 cm^2 .

FOR INVESTIGATION

20.1 What is the total area of the four white hexagons that form part of each tile?

21. The diagram shows ten equal discs that lie between two concentric circles - an inner circle and an outer circle. Each disc touches two neighbouring discs and both circles. The inner circle has radius 1.

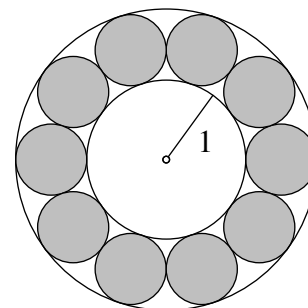

What is the radius of the *outer* circle?

- A $2 \tan 36^\circ$ B $\frac{\sin 36^\circ}{1 - \sin 36^\circ}$ C $\frac{1 + \sin 18^\circ}{1 - \sin 18^\circ}$
 D $\frac{2}{\cos 18^\circ}$ E $\frac{9}{5}$

SOLUTION

C

Let O be the common centre of the inner and outer circles, let C be the centre of one of the discs and let T be the point where one of the tangents from O meets the disc, as shown in the diagram.

Let the radius of each of the discs be r cm. We see from the diagram that the radius of the outer circle is $(1 + 2r)$ cm.

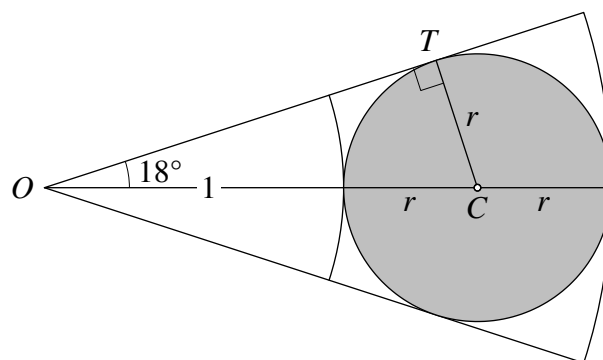

There are ten equal discs surrounding the inner circle. Therefore the angle between the two tangents from O to one of the discs is $\frac{1}{10}(360^\circ)$, that is, 36° .

Since $\angle TOC$ is one half of this angle, we have $\angle TOC = 18^\circ$.

The tangent OT is at right angles to the radius CT . Therefore TOC is a right-angled triangle in which the hypotenuse, OC , has length $(1 + r)$ cm, and the side opposite the angle of 18° has length r cm.

It follows that

$$\sin 18^\circ = \frac{r}{1 + r}.$$

From this equation we deduce that

$$(1 + r) \sin 18^\circ = r,$$

and hence that

$$\sin 18^\circ = (1 - \sin 18^\circ)r.$$

It follows that

$$r = \frac{\sin 18^\circ}{1 - \sin 18^\circ}.$$

Therefore the radius of the outer circle is given by

$$1 + 2r = 1 + \frac{2 \sin 18^\circ}{1 - \sin 18^\circ} = \frac{(1 - \sin 18^\circ) + 2 \sin 18^\circ}{1 - \sin 18^\circ} = \frac{1 + \sin 18^\circ}{1 - \sin 18^\circ}.$$

22. Three friends make the following statements.

Ben says, "Exactly one of Dan and Cam is telling the truth."

Dan says, "Exactly one of Ben and Cam is telling the truth."

Cam says, "Neither Ben nor Dan is telling the truth."

Which of the three friends is lying?

A Just Ben

B Just Dan

C Just Cam

D Each of Ben and Cam

E Each of Ben, Cam and Dan

SOLUTION

C

If Cam's statement is true, then both Ben and Dan are lying. But then exactly one of Ben and Cam is telling the truth. So Dan is telling the truth. This is a contradiction.

We deduce that Cam is lying.

Hence at least one of Ben and Dan is telling the truth.

If Ben's statement is true, then exactly one of Ben and Cam is telling the truth. Hence Dan is telling the truth.

Similarly, if Dan's statement is true, then Ben is telling the truth.

We deduce that Ben and Dan are telling the truth and that Cam is lying.

FOR INVESTIGATION

22.1 Four friends make the following statements.

Ben says, "Exactly one of Cam, Dan and Sam is telling the truth."

Dan says, "Exactly one of Ben, Cam and Sam is telling the truth."

Cam says, "Exactly one of Ben, Dan and Sam is telling the truth."

Sam says, "None of Ben, Dan and Cam is telling the truth."

What can you deduce about who is telling the truth and who is lying?

23. A cuboid has sides of lengths 22, 2 and 10. It is contained within a sphere of the smallest possible radius.

What is the side-length of the largest cube that will fit inside the same sphere?

A 10

B 11

C 12

D 13

E 14

SOLUTION

E

If a cuboid is contained in a sphere of the smallest possible radius, the vertices of the cuboid will lie on the sphere. It follows that the diagonals of the cuboid will be diameters of the sphere. So we begin by calculating the length of the diagonals of the $22 \times 2 \times 10$ cuboid.

Consider a general cuboid with sides of lengths a , b and c , as shown in the diagram. Let P , Q , R and S be the vertices shown in this diagram. Let d be the length of the diagonal RS .

By Pythagoras' theorem, applied to the right-angled triangle PQR , we have

$$PR^2 = a^2 + b^2.$$

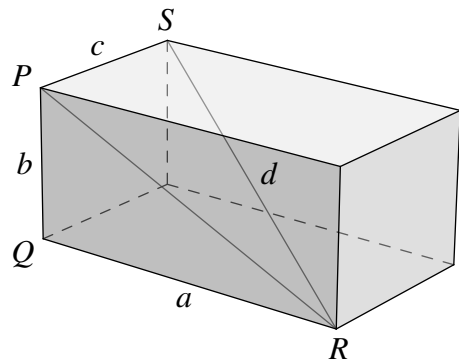

Therefore, by Pythagoras' theorem, applied to the right-angled triangle, SPR , we have

$$d^2 = PR^2 + c^2 = a^2 + b^2 + c^2.$$

It follows that for the cuboid given in the question,

$$d^2 = 22^2 + 2^2 + 10^2 = 484 + 4 + 100 = 588.$$

Therefore the smallest sphere inside which the cuboid will fit has diameter d , where $d = \sqrt{588}$.

Let s be the side length of the largest cube that will fit inside this sphere. By the equation $d^2 = a^2 + b^2 + c^2$ for the diagonal of a cuboid, we have

$$d^2 = s^2 + s^2 + s^2,$$

and hence

$$588 = 3s^2.$$

It follows that $s^2 = 196$, and hence $s = 14$.

FOR INVESTIGATION

23.1 Note that, in the above solution, we have

$$3s^2 = 22^2 + 2^2 + 10^2.$$

Find examples of three different positive integers a , b and c , with no common factor other than 1, such that there is a positive integer s such that

$$3s^2 = a^2 + b^2 + c^2.$$

24. The diagram shows a square $PQRS$. The arc QS is a quarter circle. The point U is the midpoint of QR and the point T lies on SR . The line TU is a tangent to the arc QS .

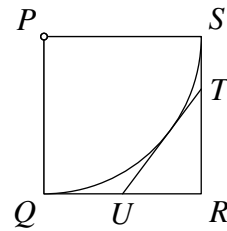

What is the ratio of the length of TR to the length of UR ?

- A 3 : 2 B 4 : 3 C 5 : 4 D 7 : 6 E 9 : 8

SOLUTION

B

It is convenient, because U is the midpoint of QR , to choose units so that the square has sides of length 2. It follows that each of UQ and UR has length 1.

Suppose that TR has length x . Then the length of TS is $2 - x$.

Let V be the point where the line TU is tangent to the arc.

Because the two tangents from a point to a circle have the same length, $UV = UQ = 1$ and $VT = TS = 2 - x$. It follows that $UT = UV + VT = 1 + (2 - x) = 3 - x$.

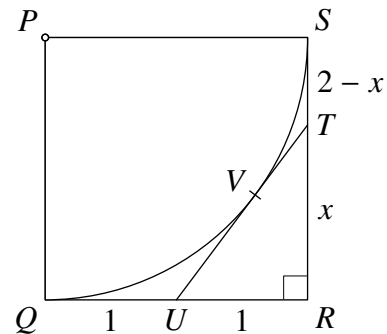

In the right-angled triangle URT the hypotenuse has length $3 - x$, and the other two sides have lengths 1 and x . Therefore, by Pythagoras' theorem applied to this triangle,

$$1^2 + x^2 = (3 - x)^2.$$

It follows that

$$1 + x^2 = 9 - 6x + x^2,$$

and hence

$$6x = 8.$$

We deduce that $x = \frac{4}{3}$.

Therefore $TR : UR = \frac{4}{3} : 1 = 4 : 3$.

FOR INVESTIGATION

24.1 Prove that the two tangents from a point to a circle have the same length.

24.2 In this question the common length of the sides of the square $PQRS$ is not given. Why is it legitimate in answering this question to choose units so that this length is 2?

25. Let n be the smallest integer for which $7n$ has 2016 digits.

What is the units digit of n ?

A 0

B 1

C 4

D 6

E 8

SOLUTION

D

The smallest positive integer which has 2016 digits is the number 10^{2015} , which is written with the digit 1 followed by 2015 copies of the digit 0. It follows that we require n to be the least positive integer for which $7n \geq 10^{2015}$. Therefore n is the least positive integer such that

$$n \geq \frac{10^{2015}}{7}.$$

The decimal expansion of $\frac{1}{7}$ is the recurring decimal $0.\dot{1}4285\dot{7}$, with the block 142857 of six digits repeated for ever after the decimal point.

We have

$$\frac{10^{2015}}{7} = 10^{2015} \times \frac{1}{7}.$$

The effect of multiplying by 10^{2015} is to move the decimal point 2015 places to the right. It follows that the decimal representation of $\frac{10^{2015}}{7}$ consists of the digits 142857 in repeated blocks, with 2015 of these digits coming before the decimal point.

Now $2015 = 6 \times 335 + 5$. Therefore the decimal expansion of $\frac{10^{2015}}{7}$ consists of 335 repetitions of the block 142857 followed by 14285 before the decimal point, with the digit 7 followed by an unending repetition of the block of digits 142857 after the decimal point.

That is,

$$\frac{10^{2015}}{7} = 142857\ 142857 \dots 142857\ 14285\ .7\ \dot{1}4285\dot{7}.$$

It follows that the least integer n such that $n \geq \frac{10^{2015}}{7}$ is

$$142857\ 142857 \dots 142857\ 14286,$$

whose units digit is 6.

Therefore the units digit of the least positive integer n for which $7n$ has 2016 digits is 6.

FOR INVESTIGATION

25.1 Check that the decimal expansion of $\frac{1}{7}$ is $0.\dot{1}4285\dot{7}$.

25.2 Which is the smallest integer n for which $3n$ has 1000 digits?

25.3 Which is the smallest integer n for which $13n$ has 100 digits?